

1/48^{scale}

PRECISE CARD MODEL

SUPERMARINE SPITFIRE Mk II a

9

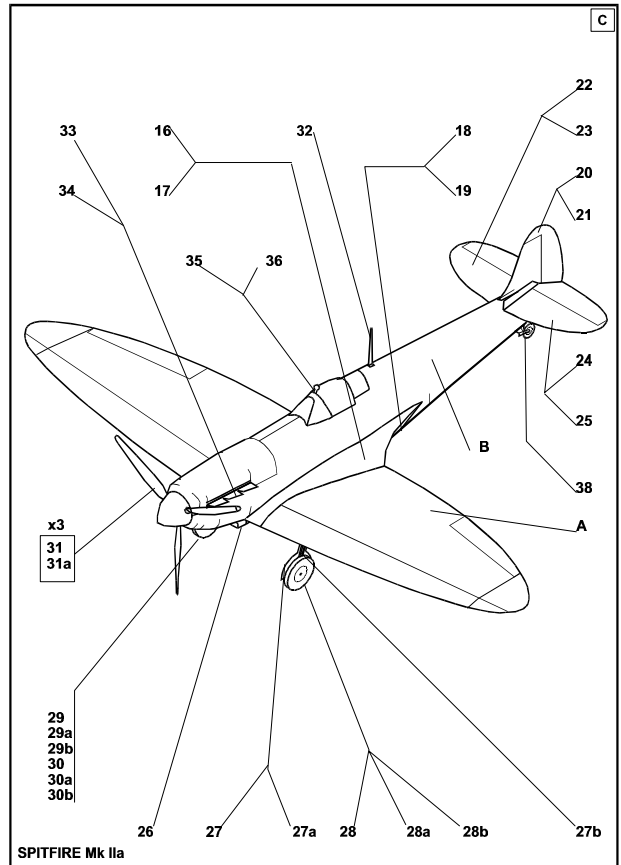
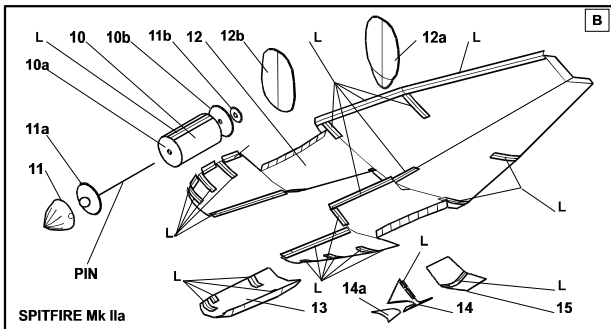
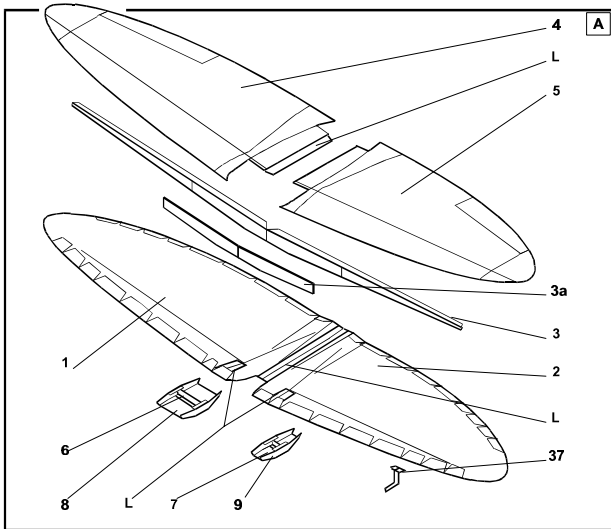

ASSEMBLY INSTRUCTION

Print the kit on color printer with maximal resolution.
Use special coated paper.

You can use pencils and water based paints
to weather the model before cutting its parts.



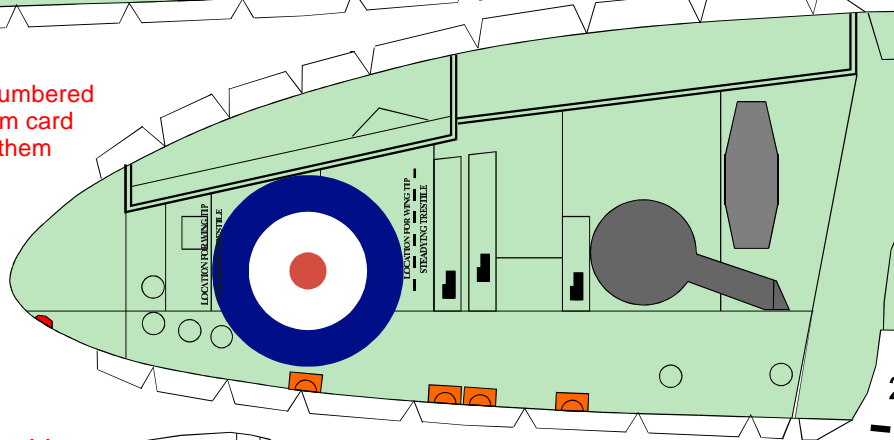
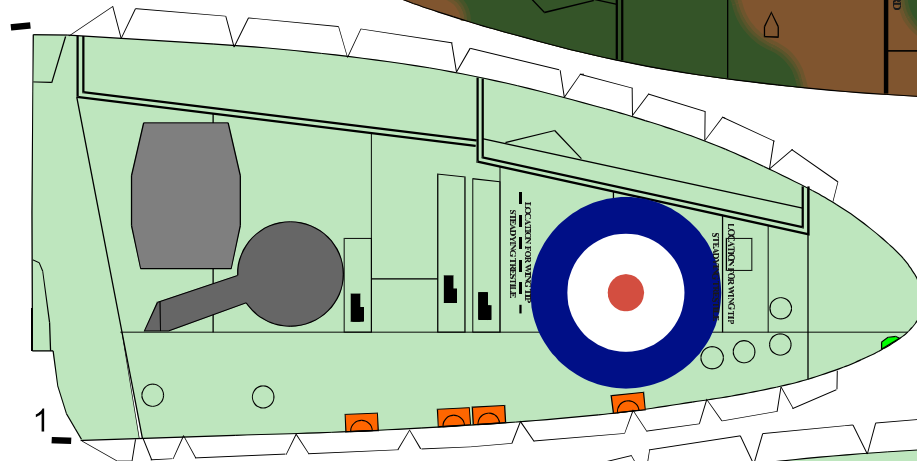
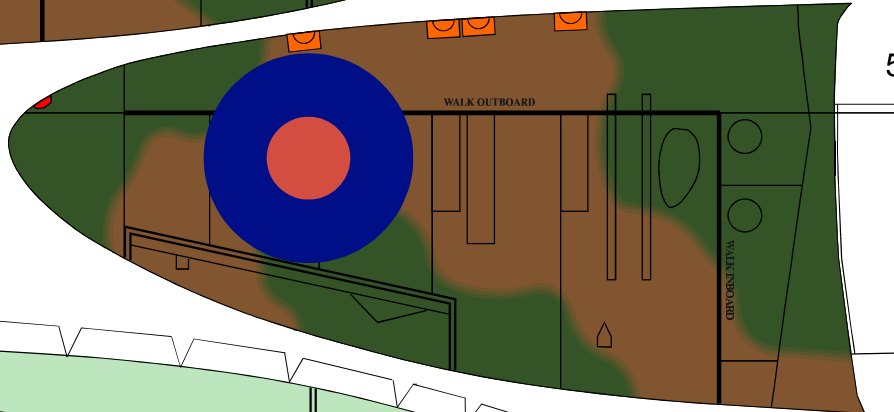
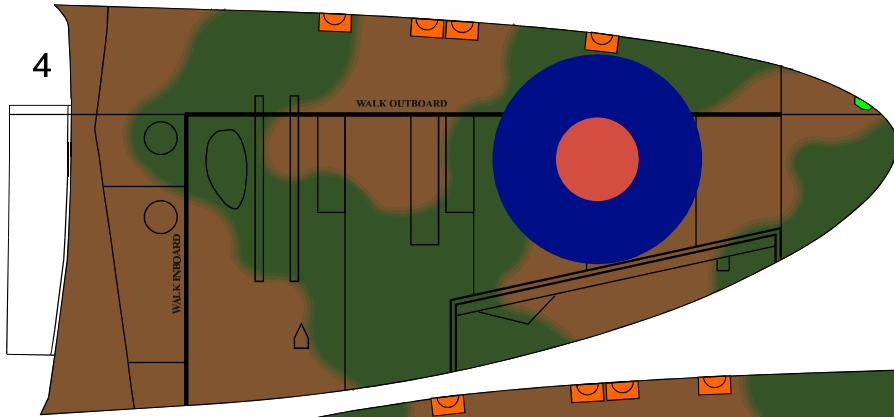

Glue the red numbered parts on 0.3 mm card before cutting them



30b 27b

11b



11a

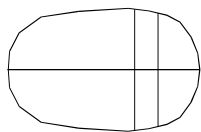

12b



10b



10a

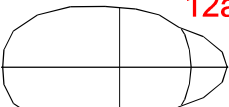

12a



28



29



28a



29a



28b



29b

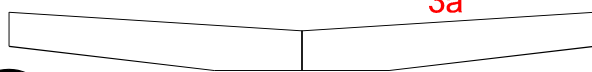

3a

3

Pattern for connecting stripes

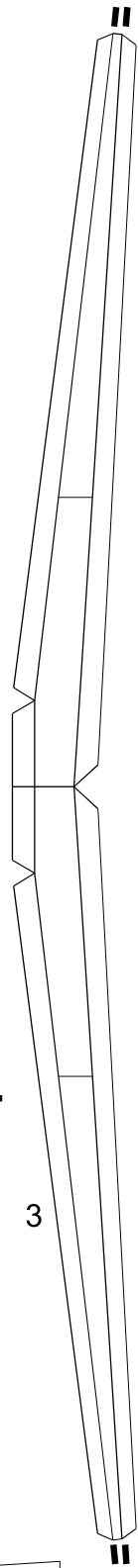

ASSEMBLY INSTRUCTION

Study drawings of assembly steps carefully before starting the work on the model. Make sure you understand the purpose and place of every part.

The assembly requires some basic tools, such as scissors, sharp modeling knife, blunt knife for scoring the fold lines, ruler and needle. Additional materials you need are one pin to make the propeller's shaft and a piece of cardboard approx. 0.3 mm thick for reinforcing elements and wheels. You'll need of course suitable cement too. For cement application you can use toothpicks or some similar tool (special fine cement applicator is most suitable if you have one).

First of all you must score with the blunt knife all fold lines shown on the cutouts with short thick marks near the parts. To avoid mistakes and lost parts cut the necessary details shortly before their use.

Start with the wing. Cut lower halves 1 and 2 and don't forget the cut in their front part near the wing root, which is necessary to form the wing's V-shape later. Bend the joint elements inwards and carefully form each half. Try to represent the characteristic shape of the wing - fuselage joint, as shown on the drawing. Cut from joint elements [L] stripes with suitable length and use them to assemble the wing's lower part from the two halves. Cut and bend the wing's part 3 and cement the reinforcing element 3a to it.

Cut and shape the upper halves of the wing. Cement the spar 3 to the wing's lower part. Test the fit of the wing's upper and lower parts and cement them together. Watch out for the wing profile and avoid warping.

Drill holes in the center of the forming parts 10a and 10b, then make the cylindrical body 10 through which the propeller's axle is protruding.

Make the propeller's shaft cementing the pin's head to the forming part 11a, as shown on the drawing. The pin must be coaxial with the cylinder's 10 centerline. Put the pin into the cylinder, then cement the limiting disc 11b on the pin's rear end. The propeller's shaft must turn free in the cylinder's body, but with minimal clearance. Then make and cement the spinner 11 to the forming part 11a.

Cut the fuselage 12 and pay attention to the cuts in it - you must make them with maximal accuracy. Cut the forming parts 12a and 12b and make the necessary joint elements [L]. Carefully shape the fuselage - all edges of the small cuts must join together and then must be reinforced with [L] elements cemented from inside. Give diptical shape to the fuselage and cement it starting from

the rear lower section. Be careful and avoid warping. Put the bulkhead 12a on its place and cement it to the fuselage. It's a very tricky job and requires special attention. Any inaccuracy will result in fuselage warping or crooking. The same is valid for the front lower fuselage part. When this fuselage section is ready too, put the fire wall 12b inside and cement the cylinder-shaft-spinner subassembly to the nose fuselage part. Be extremely careful - use cement sparingly to prevent cementing of the rotating shaft. Make the upper part of the engine cowling 13 as shown on the drawing and cement it to the fuselage. Don't forget that the propeller shaft's axle (i.e. the pin) must be coaxial with fuselage centerline.

The next step is the canopy - parts 14, 14a and 15. You have a choice of normal or armored windshield for the canopy. Alternative parts are with the same numbers, but the number's color is dark blue.

Make the canopy, cement it on its place; then cement the assembled wing to the fuselage. Beware of any warping and crooking.

Cut the aerodynamic wing-fuselage joints 16, 17, 18 and 19. Parts 16 and 17 must have double-curved shape. To ease your job cut parts 16 and 17 on some places. The cuts must be perpendicular to their contour lines. For cleaner job it's recommended to apply cement not on these parts, but on their attachment points on the wing and fuselage.

Cut and assemble the horizontal and vertical tail (parts 20 - 25) and cement them to the fuselage as shown on the drawing.

Now it is time for details - oil and cooling liquid radiators, armament, propeller's blades, antenna's mast, rear view mirror, exhausts and carburetor's air intake. Follow the instruction drawings for their assembly.

If you want to have an aircraft with extended landing gear, make the wheels from cardboard (parts 28, 28a, 28b; 29, 29a and 29b) and paint their edges with suitable paint - water based or acrylic; the easiest way is to use black marker.

If you prefer a flying model, make your aircraft with retracted main landing gear. In this case you can omit parts 10, 10a, 10b; 11b; 27, 27b; 28, 28a, 28b; 29, 29a, 29b; 30, 30b; 31 and 31a, using only the forming part 11a for the fuselage front part. Put some weight in the nose to balance the flying model. The model's center of gravity must be on approx. 25% from the wing chord.

Now your model is ready. Enjoy your Spitfire!